

Zawias równoległy KT
Parallel hinge KT
Петля под фальшпанель KT



ZASTOSOWANIE / APPLICATION / ПРИМЕНЕНИЕ



PARAMETRY / CHARACTERISTICS / ХАРАКТЕРИСТИКИ

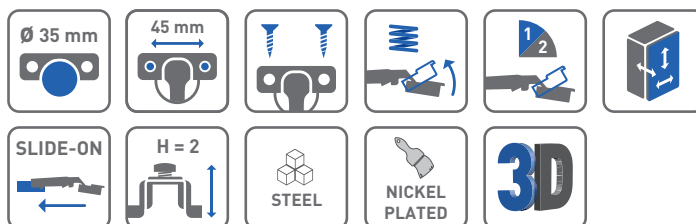

OPCJE ZESTAWU / SET OPTIONS / КОМПЛЕКТАЦИЯ



PAKOWANIE / PACKING / УПАКОВКА



SKŁAD ZESTAWU / SET INCLUDES / КОМПЛЕКТАЦИЯ



ZAWIAS RÓWNOLEGŁY
PARALLEL HINGE
ПЕТЛЯ ПОД ФАЛЬШПАНЕЛЬ

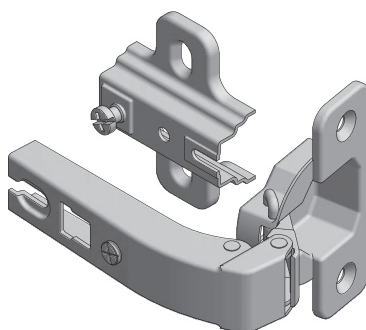

H2	ZP-KT90H2-BE	—	—
	ZP-KT90H2-ZE	—	x 2

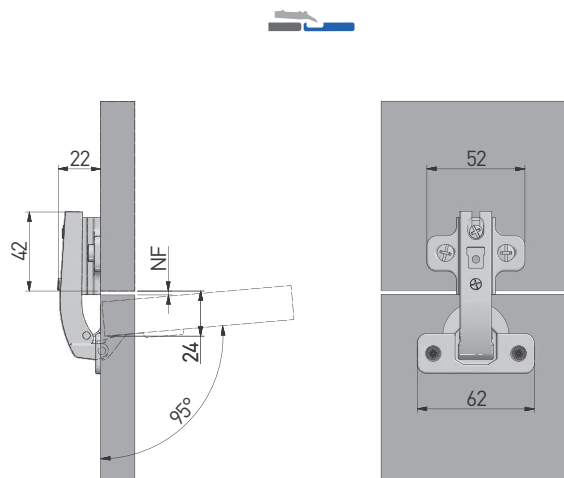

MONTAŻ / MOUNTING / МОНТАЖ

montaż prowadnika w korpusie
mounting plate installation
присадка под ответную планку

montaż puszki we froncie
hinge cup installation
присадка под чашку петли

*		
	ø 2	ø 5

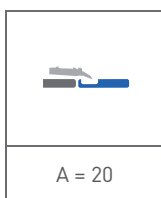
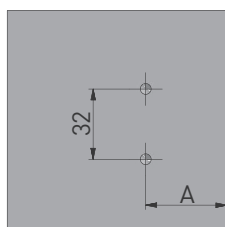
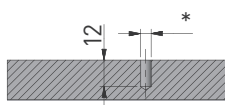

A = odległość prowadnika od krawędzi (mm)
gap between mounting plate
and the cabinet edge (mm)
расстояние от ответной планки
до края (мм)

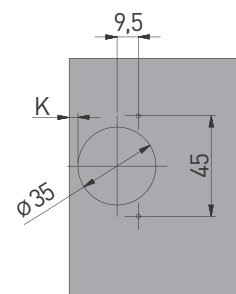

	NF	-4	-3	-2	-1	0
H = 2	K			3	4	5

NF = natożenie frontu (mm)
front overlay (mm)
наложение фасада (мм)

K = odległość puszki od krawędzi (mm)
gap between hinge cup and cabinet edge (mm)
расстояние от чашки петли до края (мм)

H = wysokość prowadnika
mounting plate height
высота ответной
планки

Gf = grubość frontu
front thickness
толщина фасада

REGULACJA / ADJUSTMENT / РЕГУЛИРОВКА



± 2 mm



± 2 mm



± 2 mm