

Noga F-50 składana\*  
 Leg F-50 foldable\*  
 Складная опора F-50\*

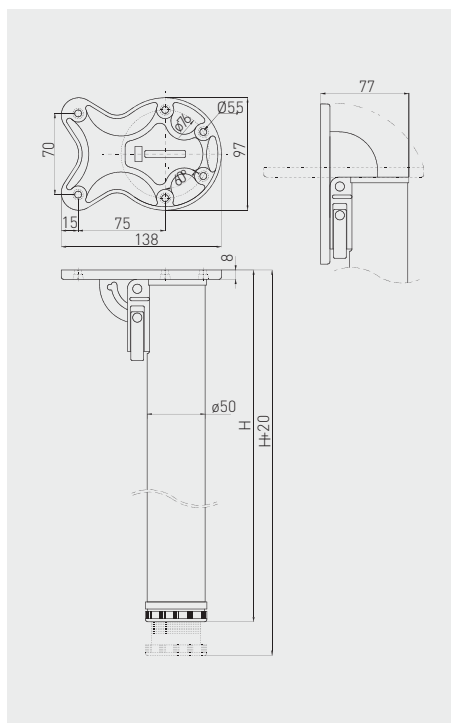

		 H mm			
NM-F50710-01	710 + 20		chrom / chrome / хром	ZnAl, stal, ABS ZnAl, steel, ABS ZnAl, сталь, ABS	8
NM-F50710-06			stal szczotkowana / brushed steel / шлифованная сталь		
NM-F50710-10			biały / white / белый		
NM-F50710-20			czarny / black / чёрный		
NM-F50870-01	870 + 20		chrom / chrome / хром		
NM-F50870-06			stal szczotkowana / brushed steel / шлифованная сталь		
NM-F50870-10			biały / white / белый		
NM-F50870-20			czarny / black / чёрный		

\* Dostępny na zamówienie / Available only for individual order / Доступен под заказ